

## SUPPORT INSULATOR: APR-210

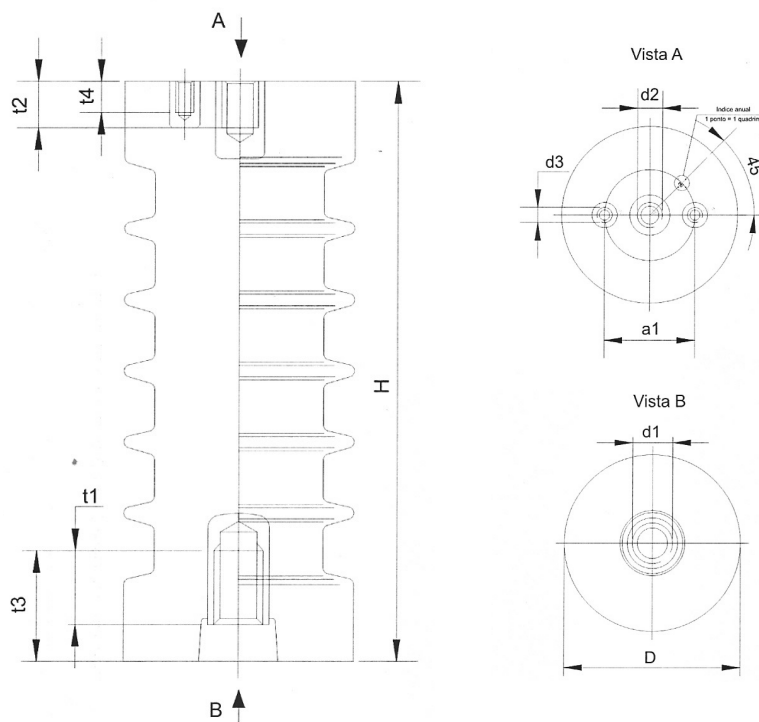

### Description

Indoor support insulators made of epoxy resin.  
Outdoor support insulators made of cycloaphlic epoxy resin.

### Dimensions (mm)

H	∅D	d1	d2	d3	a1	t1	t2	t3	t4
210	70	M16	M12	M6	36	30	15	45	9

### Electrical Ratings

Nominal voltage: 24 kV  
High voltage pulses: 125 kV  
Creepage distance: 305 mm

### Mechanical Ratings

Approximate weight: 1,1 Kg.  
Bending Strength: 5 kN  
Number of sheds: 6  
Screw Pitch: UNE 21-110-83

### Indoor Model: APR-210

### Outdoor Model: APR-210/EXT



Pol. Ind. Can Tapioles  
c/Narcís Monturiol, 4 nave 10  
08110 MONTCADA-REIXAC (Barcelona) SPAIN  
e-mail: [comercial@proat.es](mailto:comercial@proat.es)  
[www.proat.es](http://www.proat.es)